

SENOVEN[®]

FRONT OPERATED DOUGH SHEETER

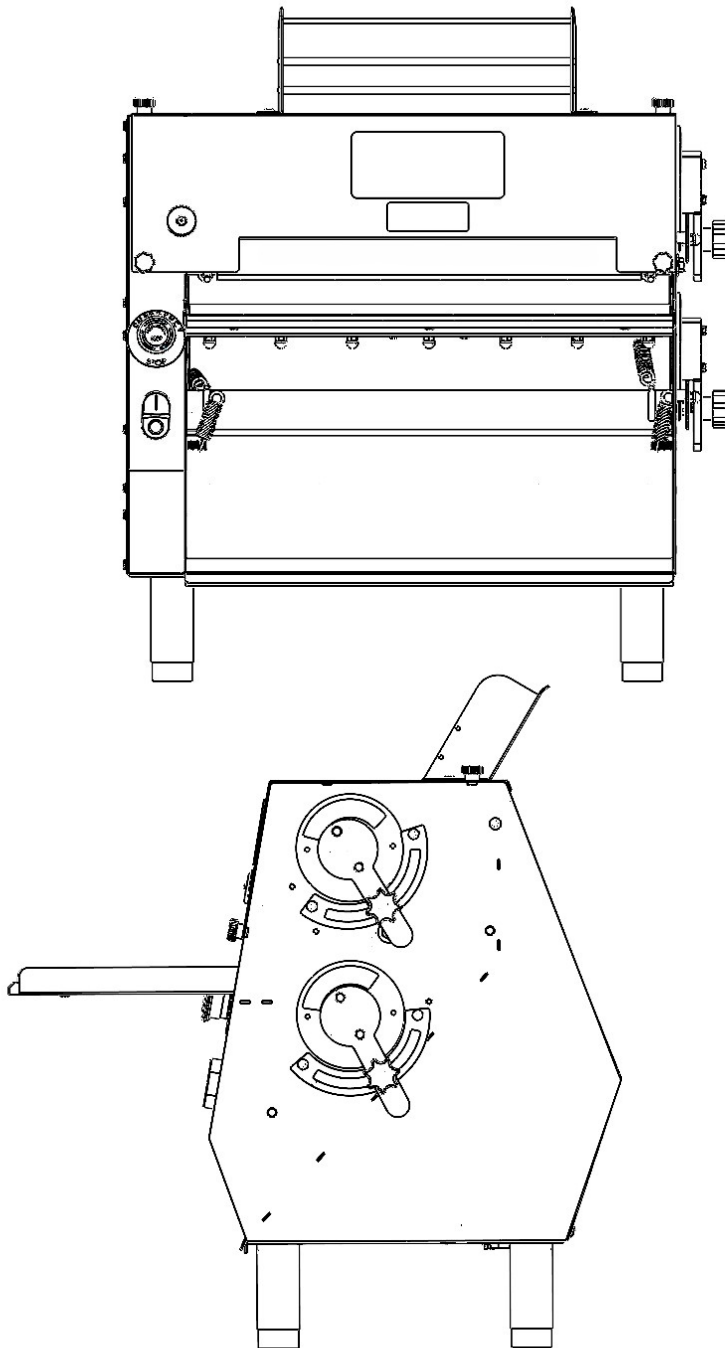

SMA-500 NA



Intertek



Features

- Perfect for fondant, pizza, pita and tortilla dough.
- 3.46" diameter rollers for dough handling.
- The roller gap can be adjusted up to 0.39".
- SMA-500 NA can roll up to 500 - 600 pcs. of dough per hour regarding their weight and thickness.
- SMA-500 NA, thanks to their dimensions, are so easy to set, use, and clean.
- They work silently and vibration-free.
- Fully stainless body and other machine elements pursuant to food norms.
- The machines are produced in accordance with the standards of various countries, especially Europe and America.

Technical Specifications

Model	SMA-500 NA
Roller Size	20"
Unit Dimensions	
Width	24.80"
Depth	24.41"
Height	27.56"
Unit Weight	149.91 lbs
Shipping Dimensions	
Width	28.15"
Depth	28.15"
Height	33.62"
Shipping Weight	197.53 lbs

Electrical Requirements	Voltage	Phase	Frequency	Total Power	Amps
Single Plus Dough Sheeters	110/120 VAC	1 Phase	60 Hz	1/2 HP	6,8A